

D.

válvulas | *valves* |

gas





índice

index / index / indice



SERIE MIÑO 2000 <i>MIÑO 2000 SERIES</i>	02
SERIE TER <i>TER SERIES</i>	04
SERIE V-82 <i>V-82 SERIES</i>	10
SERIE V-83 <i>V-83 SERIES</i>	13
SERIE V-90 <i>V-90 SERIE</i>	14
CÓLECTORES DUPLO TER <i>DOUBLE COLLECTORS TER</i>	15
ACCESÓRIOS DE GAS <i>ACCESSORIES FOR GAS VALVES</i>	16
VÁLVULAS GAS INTERNACIONAL <i>GAS INTERNACIONAL VALVES</i>	20
CARACTERÍSTICAS TÉCNICAS <i>TECHNICAL DATA</i>	22
CERTIFICADOS DE GAS <i>GAS CERTIFICATES</i>	30



presentación

presentation / presentation / apresentação



English

With more than 30 years experience in manufacturing gas appliances, **ARCO** has become a brand name that stands for quality and warranty, a company with a known prestige and reputation. **ARCO** has based such success on a high product quality and consequently on our clients' trust.

Español

Con más de 30 años de experiencia en la fabricación de válvulas de gas, **ARCO** es hoy sinónimo de calidad y garantía. Una empresa de reconocido prestigio en todo el mundo que basa su liderazgo en la gran calidad de sus productos y en la fidelidad y confianza de todos sus clientes. Profesionales con los que **ARCO** ha adquirido un firme compromiso para ofrecer siempre la mayor calidad y el mejor servicio.

Português

Com mais de 30 anos de experiência no fabrico de válvulas de gás, **ARCO** é hoje em dia sinónimo de qualidade e garantia. Uma empresa de reconhecido prestigio em todo o mundo que baseia a sua liderança na grande qualidade dos seus produtos e na fidelidade e confiança de todos os seus clientes. Profissionais com os quais a **ARCO** adquiriu um compromisso firme para oferecer sempre a maior qualidade e o melhor serviço.

Française

Avec plus de 30 ans d'expérience dans la production de vannes gaz, **ARCO** est aujourd'hui synonyme de qualité et garantie. Une société reconnue pour son prestige dans le monde entier qui base sa position de Leader - sur la grande qualité de ses produits et la fidélité et la confiance de tous ses clients. Professionnels avec lesquels **ARCO** a acquis un solide partenariat pour leur offrir toujours les plus hauts standards de qualité et le meilleur service.



miño 2000

MIÑO 2000 H-H PALANCA

MIÑO 2000 F-F LEVER



MIÑO 2000 M-H PALANCA

MIÑO 2000 M-F LEVER

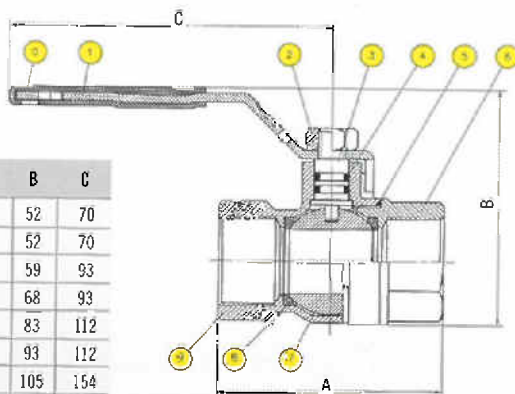

Ref.	DN	A	B	C
M1100	1/4"	44	52	70
M1101	3/8"	44	52	70
M1102	1/2"	60	59	93
M1103	3/4"	66	68	93
M1104	1"	80	83	112
M1105	1 1/4"	89	93	112
M1106	1 1/2"	108	105	154
M1107	2"	125	117	154
M1108	2 1/2"	150	142	172

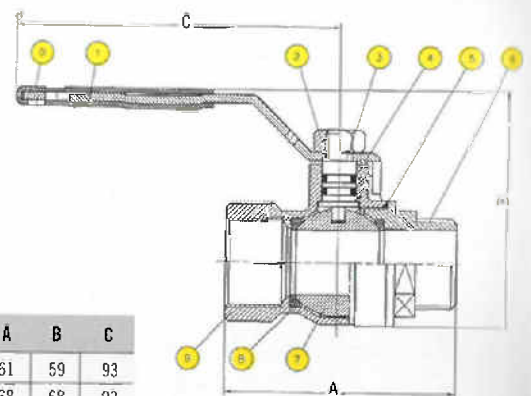

Ref.	DN	A	B	C
M1127	1/2"	61	59	93
M1129	3/4"	68	68	93
M1131	1"	87	83	112

CARACTERÍSTICAS TÉCNICAS / TECHNICAL DATA

PRODUCTO CON CERTIFICADO DE CONFORMIDAD
A LA DIRECTIVA 90/396/CE EMITIDO POR AENOR
CERTIFICATE OF CONFORMITY PER DIRECTIVE
90/396/CE BY AENOR

ITEM N°	DENOMINACIÓN	MATERIAL
ITEM N°	DESCRIPTION	MATERIAL
0	FUNDA MANDO / COVER	PÓLITILENO / PE
1	MANDO / HANDLE	ACERO / STEEL
2	TUERCA / NUT	ACERO / STEEL
3	EJE / STEM	LATÓN / BRASS
4	JUNTA TORICA / O-RING	NBR
5	JUNTA TORICA / O-RING	NBR
6	LATERAL / LATERAL	LATÓN / BRASS
7	BOLA / BALL	LATÓN / BRASS
8	ASIENTO / SEAT	PTFE
9	CUERPO / BODY	LATÓN / BRASS

MIÑO 2000 H-H MARIPOSA

MIÑO 2000 F-F BUTTERFLY



MIÑO 2000 M-H MARIPOSA

MIÑO 2000 M-F BUTTERFLY

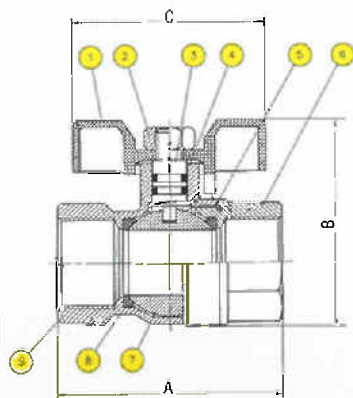

Ref.	DN	A	B	C
M1113	1/2"	60	51	56
M1114	3/4"	66	60	56
M1115	1"	80	74	80

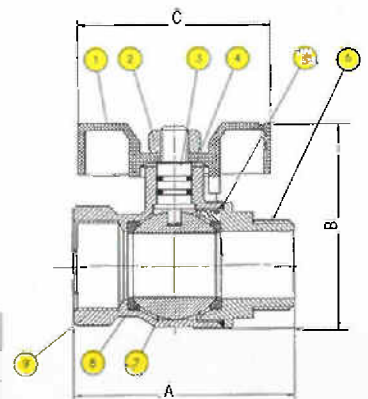

Ref.	DN	A	B	C
M1128	1/2"	61	51	56
M1130	3/4"	68	60	56
M1132	1"	87	74	80

PRODUCTO CON CERTIFICADO DE CONFORMIDAD
A LA DIRECTIVA 90/396/CE EMITIDO POR AENOR
CERTIFICATE OF CONFORMITY PER DIRECTIVE
90/396/CE BY AENOR

ITEM N°	DENOMINACIÓN	MATERIAL
ITEM N°	DESCRIPTION	MATERIAL
1	MANDO / HANDLE	ZAMAK
2	TUERCA / NUT	ACERO / STEEL
3	EJE / STEM	LATÓN / BRASS
4	JUNTA TÓRICA / O-RING	NBR
5	JUNTA TÓRICA / O-RING	NBR
6	LATERAL / LATERAL	LATÓN / BRASS
7	BOLA / BALL	LATÓN / BRASS
8	ASIENTO / SEAT	PTFE
9	CUERPO / BODY	LATÓN / BRASS

TER M-M PALANCA

TER M-M LEVER



TER M-M MARIPOSA

TER M-M BUTTERFLY

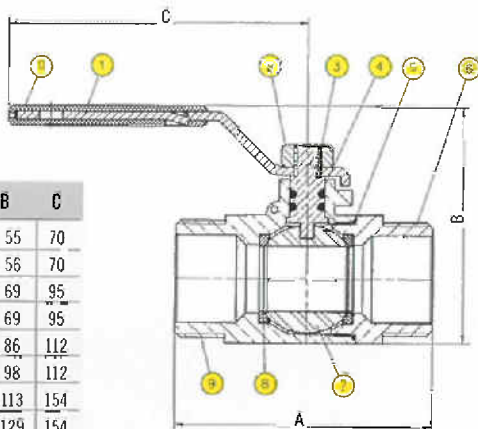

Ref.	DN	A	B	C
00516	1/2"	55	55	70
00501	3/4"	65	56	70
00530	3/4" C.G.	65	69	95
00503	1"	75	69	95
00505	1 1/4"	85	86	112
00507	1 1/2"	100	98	112
00508	2"	125	113	154
00509	2 1/2"	140	129	154

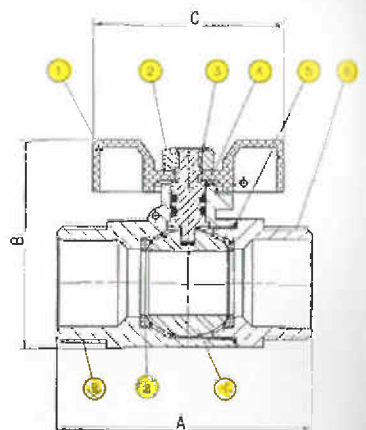

Ref.	DN	A	B	C
00517	1/2"	55	52	56
00502	3/4"	65	54	56
00500	3/4" C.G.	65	60	56
00504	1"	75	60	56
00506	1 1/4"	85	76	80

CARACTERÍSTICAS TÉCNICAS / TECHNICAL DATA

PRODUCTO CERTIFICADO POR AENOR
AENOR CERTIFIED PRODUCT

ITEM Nº ITEM No	DENOMINACIÓN DESCRIPTION	MATERIAL MATERIAL
0	FUNDA / COVER	POLIETILENO / PE
1	MANDO PALANCA / LEVER HANDLE	ACERO / STEEL
1	MANDO MARIP. / BUTT HANDLE	ZAMAK
2	TUERCA / NUT	ACERO / STEEL
3	EJE / STEM	LATÓN / BRASS
4	JUNTA TORICA / STEM	NBR
5	JUNTA TORICA / STEM	NBR
6	LATERAL / LATERAL	LATÓN / BRASS
7	BOLA / BALL	LATÓN / BRASS
8	ASIENTO / SEAT	PTFE
9	CUERPO / BODY	LATÓN / BRASS

TER M-M CON PATAS PALANCA

TER M-M WITH FLANGE LEVER

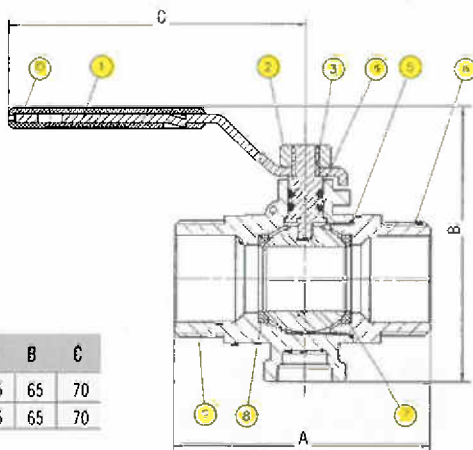

Ref.	DN	A	B	C
00604	1/2"	55	65	70
00605	3/4"	65	65	70

TER M-M CON PATAS MARIPOSA

TER M-M WITH FLANGE BUTTERFLY

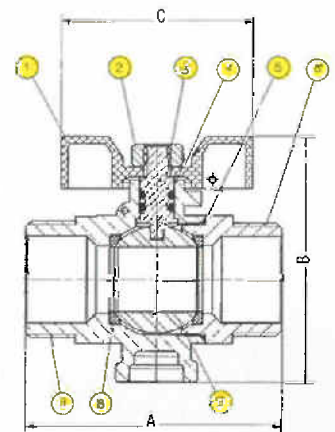

Ref.	DN	A	B	C
00603	1/2"	55	62	56
00600	3/4"	65	62	56

PRODUCTO CERTIFICADO POR AENOR
AENOR CERTIFIED PRODUCT

ITEM N° ITEM No	DENOMINACIÓN DESCRIPTION	MATERIAL MATERIAL
0	FUNDA / COVER	POLIETILENO / PE
1	MANDO PALANCA / LEVER HANDLE	ACERO / STEEL
1	MANDO MARIPOSA / BUTT. HANDLE	ZAMAK
2	TUERCA / NUT	ACERO / STEEL
3	EJE / STEM	LATÓN / BRASS
4	JUNTA TORICA / STEM	NBR
5	JUNTA TORICA / STEM	NBR
6	LATERAL / LATERAL	LATÓN / BRASS
7	BOLA / BALL	LATÓN / BRASS
8	ASIENTO / SEAT	PTFE
9	CUERPO / BODY	LATÓN / BRASS

TER M-H PALANCA

TER M-F LEVER HANDLE



TER M-H MARIPOSA

TER M-F BUTTERFLY HANDLE

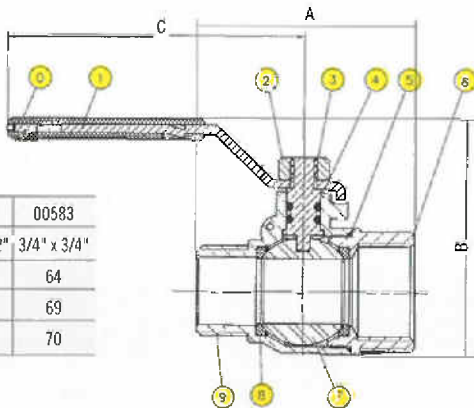

Ref.	00582	00583
DN	1/2" x 1/2"	3/4" x 3/4"
A	55	64
B	55	69
C	70	70

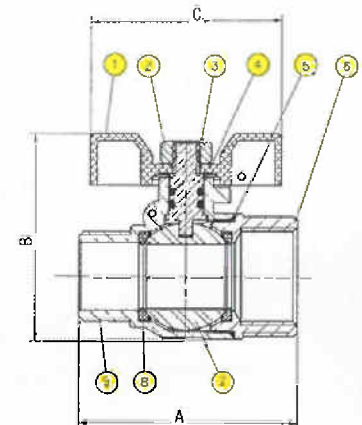

Ref.	00580	00581
DN	1/2" x 1/2"	3/4" x 3/4"
A	55	64
B	52	60
C	56	56

CARACTERÍSTICAS TÉCNICAS / TECHNICAL DATA

PRODUCTO CON CERTIFICADO DE CONFORMIDAD
A LA DIRECTIVA 90/396/CE EMITIDO POR AENOR
CERTIFICATE OF CONFORMITY PER DIRECTIVE
90/396/CE BY AENOR

ITEM N° ITEM No	DENOMINACIÓN DESCRIPTION	MATERIAL MATERIAL
0	FUNDA / COVER	POLIETILENO / PE
1	MANDO PALANCA / LEVER HANDLE	ACERO / STEEL
1	MANDO MARIPOSA / BUTT. HANDLE	ZAMAK
2	TUERCA / NUT	ACERO / STEEL
3	EJE / STEM	LATÓN / BRASS
4	JUNTA TORICA / STEM	NBR
5	JUNTA TORICA / STEM	NBR
6	LATERAL / LATERAL	LATÓN / BRASS
7	TUERCA / NUT	LATÓN / BRASS
8	JUNTA PLANA / WASHER	NBR
9	BOLA / BALL	LATÓN / BRASS
10	ASIENTO / SEAT	PTFE
11	CUERPO / BODY	LATÓN / BRASS

